

User manual

POWERWALKER INVERTER 3000 PSW



CONTENTS

<u>ABOUT THIS MANUAL</u>	1
<u>Purpose</u>	1
<u>Scope</u>	1
<u>IMPORTANT SAFETY INSTRUCTIONS</u>	1
<u>General Precautions</u>	1
<u>Personal Precautions</u>	2
<u>INSTALLATION</u>	3
<u>Unpacking and Inspection</u>	3
<u>Basic Configuration</u>	3
<u>Batteries</u>	5
<u>Battery Cable Size</u>	5
<u>DC Disconnect and Over-Current Protection</u>	5
<u>Battery Cable Connection</u>	6
<u>AC Cable Size</u>	6
<u>AC Connections</u>	7
<u>OPERATION</u>	8
<u>Front Panel and Configuration Switch</u>	8
<u>Indicator & Alarm</u>	9
<u>Operating Indicators</u>	10
<u>Setting Indicators</u>	11
<u>SPECIFICATIONS</u>	12
<u>Table 5 Line Mode Specifications</u>	12
<u>Table 6 Invert Mode Specifications</u>	13
<u>Table 7 Charge Mode Specifications</u>	14
<u>Table 8 Approximate Back-up Times</u>	15
<u>Table 9 General Specifications</u>	15
<u>Table 10 Fault code/ Audible alarm</u>	16
<u>TROUBLE SHOOTING</u>	17

ABOUT THIS MANUAL

Purpose

The purpose of this manual is to provide explanations and procedures for installing, operating and troubleshooting for the unit. This manual should be read carefully before installations and operations. Please retain this manual for future reference.

EN

Scope

This document defines the functional requirements of the unit, intended for worldwide use in electronic processing equipment. All manuals are applicable under all operating conditions when installed in the End Use system, unless otherwise stated.

IMPORTANT SAFETY INSTRUCTIONS



WARNING: This chapter contains important safety and operating instructions. Read and keep this User Guide for future reference.

General Precautions

1. Before using the unit, read all instructions and cautionary markings on:
(1) The unit (2) the batteries (3) all appropriate sections of this manual.
2. **CAUTION** --To reduce risk of injury, charge only deep-cycle lead acid type rechargeable batteries. Other types of batteries may burst, causing personal injury and damage.
3. Do not expose the unit to rain, snow or liquids of any type. The unit is designed for indoor use only. Protect the unit from splashing if used in vehicle applications.
4. Do not disassemble the unit. Take it to a qualified service center when service or repair is required. Incorrect re-assembly may result in a risk of electric shock or fire.
5. To reduce risk of electric shock, disconnect all wiring before attempting any maintenance or cleaning. Turning off the unit will not reduce this risk.
6. **CAUTION** --Battery are not already installed by the supplier only a qualified professional (e.g. service person) may install the Inverter.
7. **WARNING: WORKING IN VICINITY OF A LEAD ACID BATTERY IS DANGEROUS. BATTERIES GENERATE EXPLOSIVE GASES DURING NORMAL OPERATION.** Provide ventilation to outdoors from the battery compartment. The battery enclosure should be designed to prevent accumulation and concentration of hydrogen gas in "pockets" at the top of the compartment. Vent the battery compartment from the highest point. A sloped lid can also be used to direct the flow to the vent opening location.
8. **NEVER** charge a frozen battery.
9. No terminals or lugs are required for hook-up of the AC wiring. AC wiring must be no less than 12 AWG gauge copper wire and rated for 75°C or higher. Battery cables must be rated for 75°C or higher and should be no less than table 1. Crimped and sealed copper ring terminal lugs with a 5/16 hole should be used to connect the battery cables to the DC terminals of the unit. Soldered cable lugs are also acceptable.
10. Be extra cautious when working with metal tools on, or around batteries. The potential exists to drop a

tool and short-circuit the batteries or other electrical parts resulting in sparks that could cause an explosion.

11. No AC or DC disconnects are provided as an integral part of this unit. Both AC and DC disconnects must be provided as part of the system installation. See INSTALLATION section of this manual.
12. Fuses (F40AL, 32VDC*6) are provided as the over current protection of the battery supply.
13. **GROUNDING INSTRUCTIONS** -This battery charger should be connected to a grounded permanent wiring system. For most installations, the Ground Lug should be bonded to the grounding system at one (and only one point) in the system. All installations should comply with all national and local codes and ordinances.
14. **AVOID** AC output short-circuit; avoid DC input short-circuit and do not connect the mains while DC input short-circuit
15. **Warning:** The maintenance information is only to service persons

Personal Precautions

1. Someone should be within range of your voice to come to your aid when you work near batteries.
2. Have plenty of fresh water and soap nearby in case battery acid contacts skin, clothing, or eyes.
3. Wear complete eye protection and clothing protection. Avoid touching eyes while working near batteries. Wash your hands when done.
4. If battery acid contacts skin or clothing, wash immediately with soap and water. If acid enters eyes, immediately flood eyes with running cool water for at least 15 minutes and get medical attention immediately.
5. Baking soda neutralizes lead acid battery electrolyte. Keep a supply on hand in the area of the batteries.
6. NEVER smoke or allow a spark or flame in vicinity of a battery or generator.
7. Be extra cautious when working with metal tools on, and around batteries. Potential exists to short-circuit the batteries or other electrical parts which may result in a spark which could cause an explosion.
8. Remove personal metal items such as rings, bracelets, necklaces, and watches when working with battery. Battery can produce short-circuit current high enough to weld a ring, or the like, to metal causing severe burns.
9. If a remote or automatic generator start system is used, disable the automatic starting circuit and/or disconnect the generator from its starting battery while servicing to prevent accidental starting during servicing.

INSTALLATION

Unpacking and Inspection

Carefully unpack the inverter/charger from its shipping carton.

Verify all of items list below are present. Please call customer service if any items are missing.

- The unit
- 1 user's manual

EN

Basic Configuration

The following illustrations show basic applications for PowerWalker Inverter 3000 PSW.

They include the following configurations:

- Utility Backup. see figure 1
- Renewable Energy Source And a Generator, see figure 2

Consult with your system design for other possible configurations depending on site or code requirements.

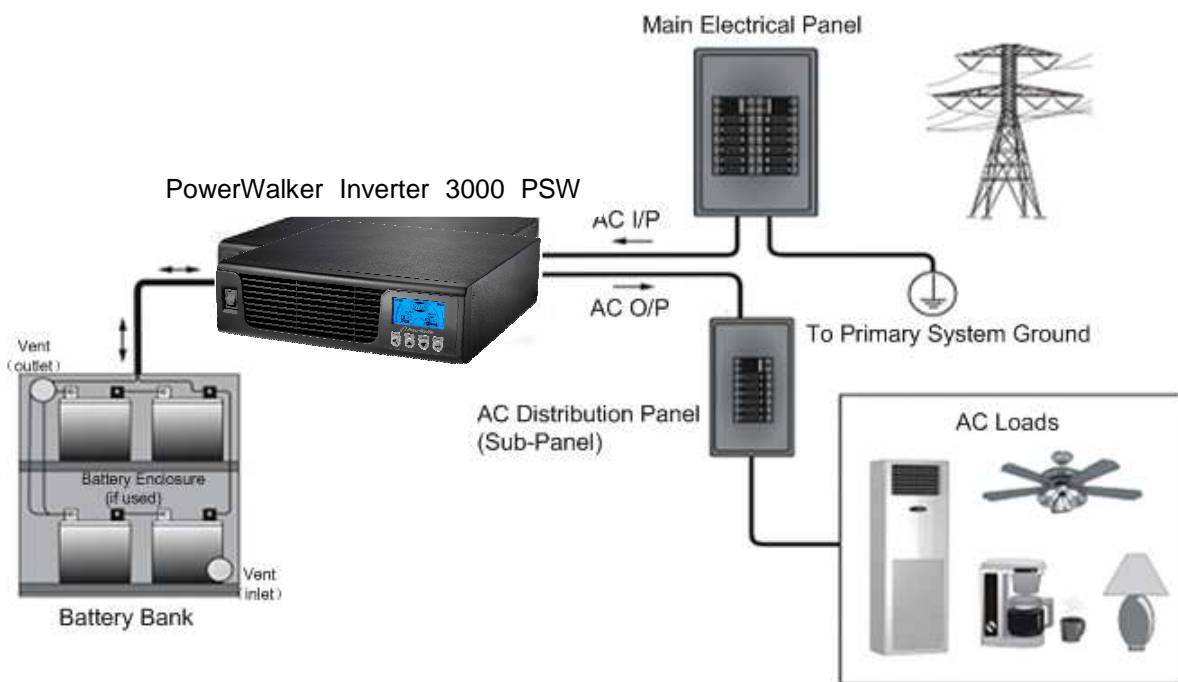

Figure 1 Utility Backup

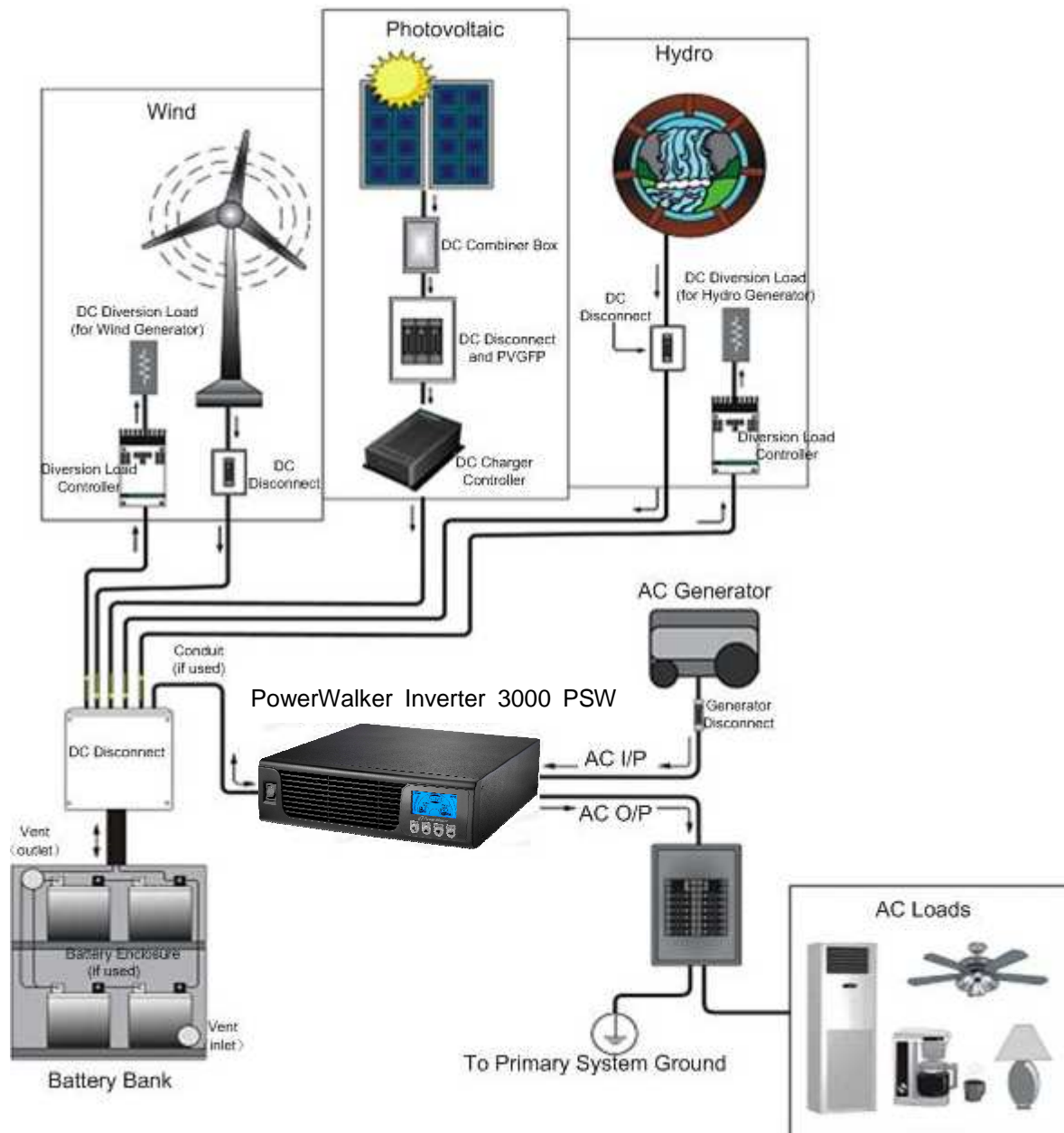

Figure 2 Renewable Energy Source

PowerWalker Inverter 3000 PSW can feeds almost all kinds of appliances from home to office environment, including motor characteristic appliances like tube light, fan, refrigerator and Air conditioner.

Note: Appliances like Air conditioner needs at least 3 minutes to restart in case of a power shortage occurs in a way that the power turns off then back on again rapidly (time is required to balance the refrigerant gas in inside circuit); so in order to protect your Air conditioner, please consult the Air conditioner manufacturer whether they have already provided time delay function before installing. Otherwise, Inverter will trig overload fault and shut off its output to protect your appliance but sometimes it is not enough and your Air conditioner can be damaged internally beyond repair.

Batteries

The unit support 24volt battery bank. Please refer to figure 3 to wiring battery correctly. Before proceeding, ensure you have appropriate size batteries for this inverter. The unit can use flooded lead-acid, or sealed GEL/AGM lead-acid batteries so ensure that your batteries are in one of these categories.

The battery must be wired to match the units DC input voltage specifications. Suggest battery capacity not smaller than 100AH.

EN

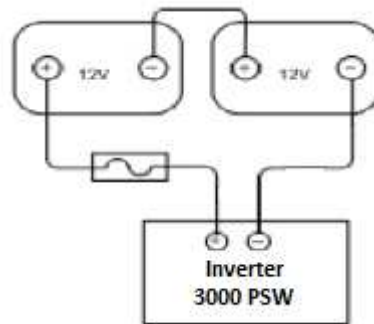

Figure 3 PowerWalker Inverter 3000 PSW batteries string wiring

Battery Cable Size

Below table 1 you can find information for recommended battery cable and terminal.

Table 1 Recommended battery cable and terminal size

Model Number	Typical Amperage	BATTERY CAPACITY	1~3 m one-way	CABLE TERMINAL	Torque value
PowerWalker Inverter 3000PSW	130A	100 AH	4 AWG or 2*8AWG	KST:RNBS22-6 (RING TYPE)	5~8 Nm
		200 AH	2* 6 AWG	KST:RNBS38-6 (RING TYPE)	5~8 Nm

DC Disconnect and Over-Current Protection

For safety and to comply with regulations, battery over-current protection and disconnect devices are required. Fuses and disconnects must be sized to protect the DC cable size used, and must be rated for DC operation. Do not use devices rated only for AC service – they will not function properly.

Note that some installation requirements may not require a disconnect device, although over-current protection is still required.

Battery Cable Connection

Observe Battery Polarity! Place the ring terminal of DC cable over the bolt and directly against the unit's battery terminal. Tighten the M6 screw with 5-8 Nm. Do not place anything between the flat part of the Backup System terminal and the battery cable ring terminal or overheating may occur.

DO NOT APPLY ANY TYPE OF ANTI-OXIDANT PASTE TO TERMINALS UNTIL AFTER THE BATTERY CABLE WIRING IS TORQUED!!

Figure 5 illustrates the proper method to connect the battery cables to the unit terminals.



WARNING: Shock Hazard

Installation must be performed with care for the high battery voltage in series.



Caution!! Do NOT place anything between battery cable ring terminals and terminals on the inverter. The terminal screw is not designed to carry current.

Apply Anti-oxidant paste to terminals AFTER terminals have been screwed.

Verify that cable lugs are flush with the battery terminals. Tighten battery cables to terminals (5-8 Nm).

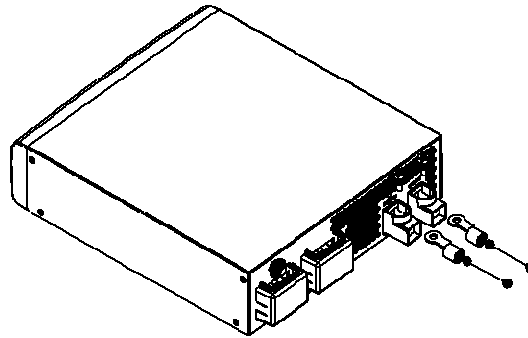

Figure 4 Battery Cable Connect to unit

AC Cable Size

Before wiring the input and output of inverter, refer to table 2 for minimum recommended cable size and torque value

Table 2 Recommended cable size and torque value for AC wire

Model Number	AC Input	AC Output	Torque value
PowerWalker Inverter 3000 PSW	12AWG	12 AWG	1.2~1.8 Nm

AC Connections

Installation should be done by a qualified electrician. Consult local code for the proper wire sizes, connectors and conduit requirements.

On the left of rear chassis is the AC hardwire cover. Two three-station terminal block is provided to make the AC connections. The terminal block is used to hardwire the AC input, AC output, and ground. The National Electrical Code requires that an external disconnect switch be used in the AC input wiring circuit. The AC breakers in a sub panel will meet this requirement.

Step 1: Disconnect the unit from the battery by removing the battery cables from the battery. Turning off the unit does not constitute disconnecting from the battery.

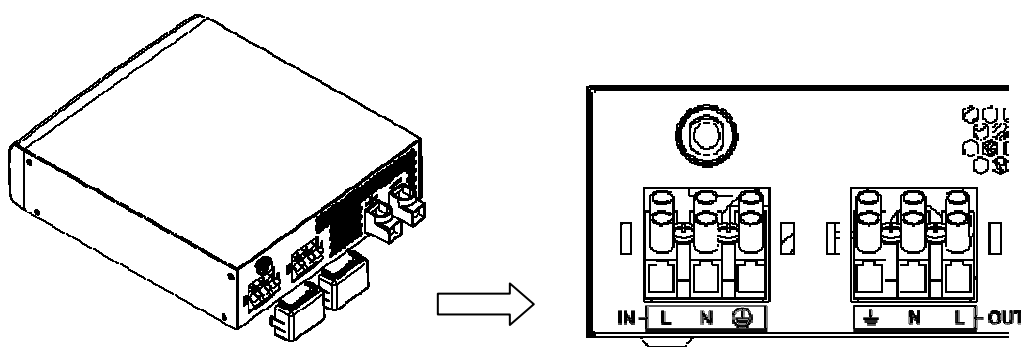

Figure 5 AC Cable Connect to unit

Step 2: Following the wiring guide located in the AC input wiring compartment as figure 5, connect the GND (green/yellow), Line (brown), and neutral (blue) wires from the AC input (utility, generator, etc) to the terminal block.



Caution!! Be sure that AC source is disconnected before attempting to hardwire it to the unit.

Step 3: Connect the AC Line output wiring to the terminal marked AC Line (output), following the wiring guide inside the compartment. Torque the wires into the terminal block.

Step 4: Lock the AC covers.

OPERATION

Front Panel and Configuration Switch

EN



Table 3 configuration button function





Switch	Function	Description
	config	Enter config mode, and turn page
	up	Move up to pre-select
	down	Move down to pre-select
	enter	Enter to confirm

Table 4 configuration pages option

Page	Description	Selectable option
1	Input range	<i>NDR U1d 6EN</i>
2	Output range	230V
3	Battery type	<i>AGN 6EL FLd</i>
4	Charger current	20A/10A
5	Saver mode	ON/OFF

Note: There are 5 configuration pages totally, change only active by enter button pressed within current page.

Indicator & Alarm

Charger mode battery indicator

Battery capacity segment will lighting to comply with battery voltage

EN

Status	CC/CV					Floating
Battery voltage(+/-0.6V)	>26V	25V~26V	24V~25V	21V~24V	<21V	Any battery voltage

Inverter mode battery indicator:

Battery voltage(+/-0.6V)	>26V	25V~26V	24V~25V	23V~24V	21.6V~23V	20V~21.6V	<20V
ALARM	--	--	--	--	--	1beep/2s	continue

Load indicator:

The load indicate the load percentage comply with load VA or W (show the bigger value), the overload label will flash when overload.

Load (±4%)	>85%	65%~85%	45%~65%	25%~45%	0%~25%

Note:

Solid on;
 On to off;
 Off.

Operating Indicators

Standby Mode:

Voltage and Frequency exchanged every 5 seconds

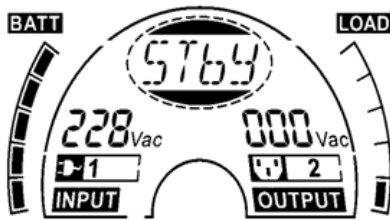

Inverter Mode:

Voltage and Frequency exchanged every 5 seconds

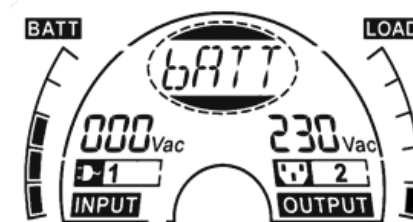

EN

Line Mode:

Voltage and Frequency exchanged every 5 seconds

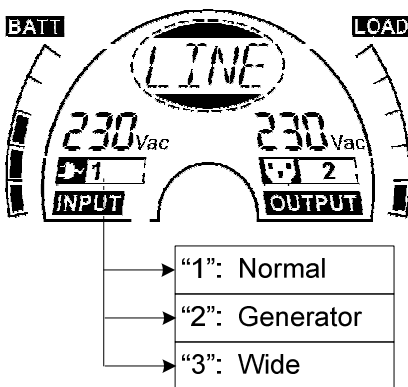

Warning Mode:

Red back light flash every 1 second

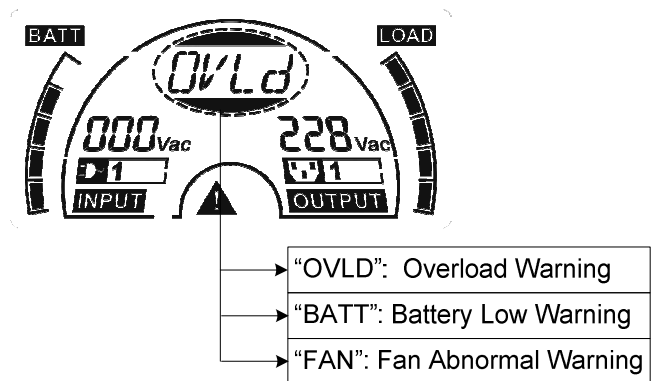

Fault Mode:

Red back light Keep on

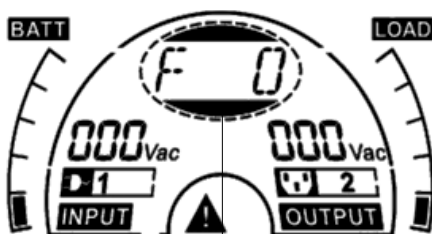

→	"F 0": Low DC Voltage	→	"F 4": Fan Fault
→	"F 1": Over Charge	→	"F 5": Over Temperature
→	"F 2": Over load	→	"F 6": Output Abnormal
→	"F 3": Output Short		

Setting Indicators

Input Range Setting

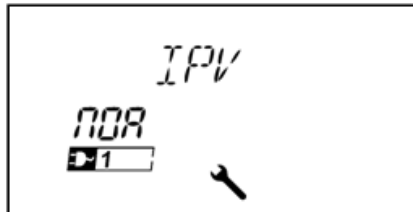

Normal mode

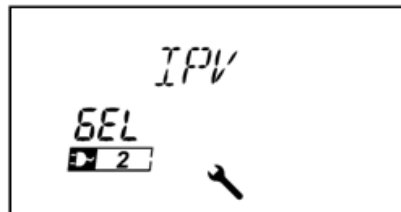

Generator mode
Generator mode

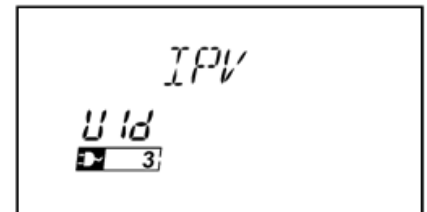

Wide mode

EN

Battery Type Setting

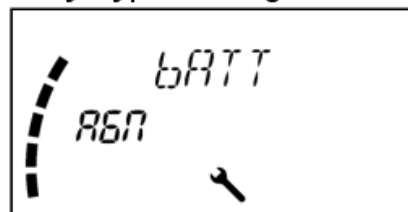

Absorption Glass Mat Battery



Gelium Battery
Battery

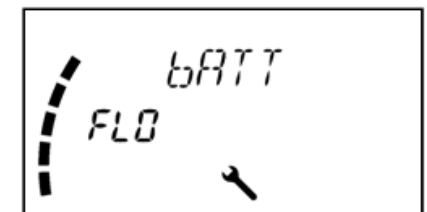

Flooded Battery

Charger Current Setting

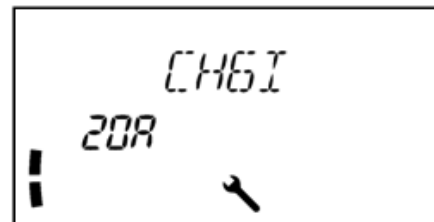

Big Current(20A)

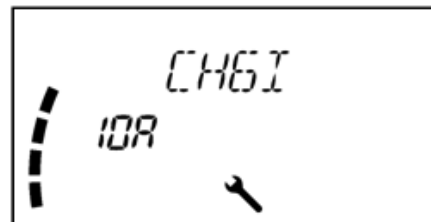

Small Current(10A)

Saver Mode Setting

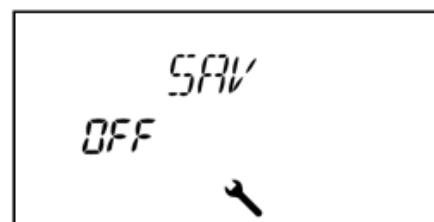

Saver Mode OFF

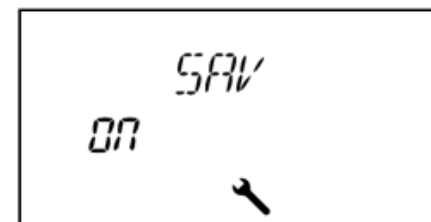

Saver Mode ON

SPECIFICATIONS

Table 5 Line Mode Specifications

EN

MODEL	PowerWalker Inverter 3000 PSW
Input Voltage Waveform	Sinusoidal (utility or generator)
Nominal Input Voltage	230Vac
Low Line Disconnect	170Vac±4%(NOR) 90Vac±4%(GEN/WID)
Low Line Re-connect	180Vac±4% (NOR) 100Vac±4% (GEN/WID) Note: 1.NOR setting can be used for general electrical appliance 2. WID setting can be used only for some special load, such as lamp, fan
High Line Disconnect	280Vac±4%
High Line Re-connect	270Vac±4%
Max AC Input Voltage	300Vac rms
Nominal Input Frequency	50Hz / 60Hz (Auto detection)
Low Line Frequency Disconnect	40±1Hz
Low Line Frequency Re-connect	42±1Hz
High Line Frequency Disconnect	65±1Hz
High Line Frequency Re-connect	63±1Hz
Output Voltage Waveform	As same as Input Waveform
Output Short Circuit Protection	30A Circuit Breaker
Efficiency (Line Mode)	>95% (Rated R load, battery full charged)
Transfer Switch Rating	30A
Transfer Time	10ms (typical) 15ms max(NOR) 20ms (typical) 40ms max(GEN/WID)
Bypass charger enable in off mode	Yes
Power Limitation	 <p>The graph plots Output Power (Y-axis) against Input Voltage (X-axis). The power is zero until 90V, then jumps to 1.5KVA/1.2KW. At 180V, it jumps to 3KVA/2.4KW and remains constant until 280V, where it drops to zero.</p>

Table 6 Invert Mode Specifications

MODEL	PowerWalker Inverter 3000 PSW
Output Voltage Waveform	Pure Sine Wave
Rated Output Power	3000VA
Power Factor	0.8
Nominal Output voltage	230Vac
Minimum Peak Output Voltage at Rated Power	>200V
Output Frequency(Hz)	50Hz / 60Hz \pm 1Hz (follow first connect to grid)
Output Voltage Regulation	\pm 10% Vrms
Nominal Efficiency	>90% (@Normal DC Input; >60% R load)
Over-Load Protection	fault after 5s @ \geq 150% load, \leq 200% load fault after 10s @ 110%~150% load,
Surge rating	6000VA
Capable of starting electric motor	1.5HP
Output Short Circuit Protection	Current limit (Fault after 4 cycles max)
Nominal DC Input Voltage	24V
Min DC start voltage	20V
Low DC Alarm	21.0 \pm 0.6Vdc
Low DC Alarm Recovery	21.6 \pm 0.6Vdc
Low DC Shut-down	20.0 \pm 0.6Vdc
Low DC Shut-down Recovery	22.0 \pm 0.6Vdc
High DC Shut-down	30.0 \pm 0.6Vdc
High DC Shut-down Recovery	29.0 \pm 0.6Vdc
DC component of output	<100mV
Power Limitation	 <p>The graph illustrates the power limitation of the inverter based on battery voltage. The y-axis represents Output power, and the x-axis represents Battery Voltage. Two power levels are shown: 3KVA/2.4KW (top) and 2.1KVA/1.68KW (bottom). The 3KVA/2.4KW level is active between 20V and 27V. The 2.1KVA/1.68KW level is active between 26.5V and 30V.</p>

EN

Table 7 Charge Mode Specifications

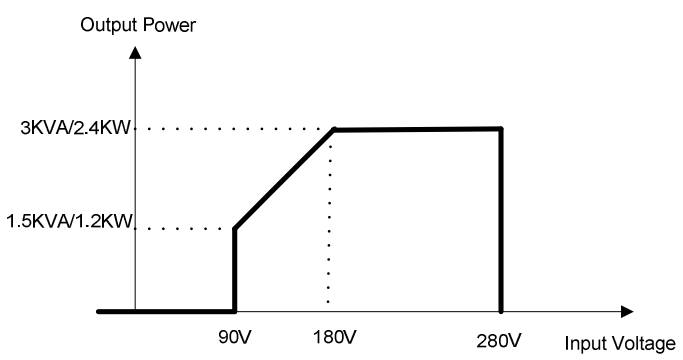
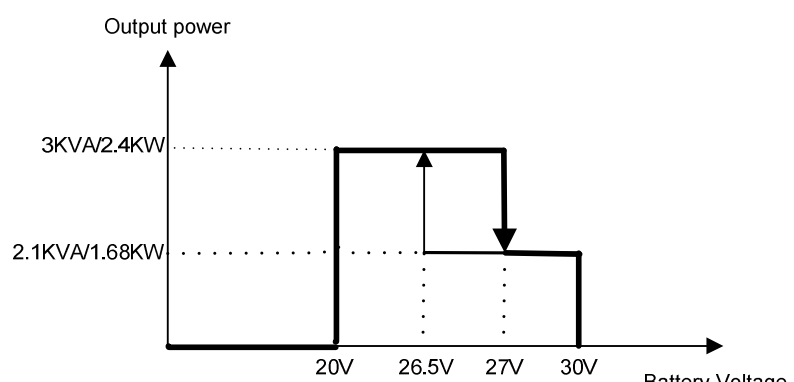
Nominal Input Voltage	230Vac														
Input Voltage Range	180V - 270Vac(NOR) 100V - 270Vac(GEN/WID)														
High Voltage Disconnect	280Vac±4%														
High Line Re-connect	270Vac±4%														
Low Voltage Disconnect	170Vac(NOR) 90Vac(GEN/WID)														
Low Line Re-connect	180Vac±4% (NOR) 100Vac±4% (GEN/WID)														
Nominal Output Voltage	Refer to Charge Algorithm/ Battery Type Setting														
Nominal Charge Current	10A @Vi/p<170Vac 20A @Vi/p=230Vac 10A @Vi/p>280Vac														
Charge current tolerance	±10%														
Over Charge Protection	Bat. V ≥30Vdc, Fault, Buzzer alarm														
Charge Algorithm	Three stage: Boost CC (constant current stage) → Boost CV (constant voltage stage) → Float (constant voltage stage)														
Battery Type Setting(+/-0.3v/bat)	<table border="1"> <thead> <tr> <th rowspan="2">Battery Type</th> <th>Boost CC/CV</th> <th>Float</th> </tr> <tr> <th>Voltage(V)</th> <th>Voltage(V)</th> </tr> </thead> <tbody> <tr> <td></td> <td>24</td> <td>24</td> </tr> <tr> <td>Flooded</td> <td>29.2</td> <td>27.0</td> </tr> <tr> <td>AGM / Gel</td> <td>28.2</td> <td>27.0</td> </tr> </tbody> </table>	Battery Type	Boost CC/CV	Float	Voltage(V)	Voltage(V)		24	24	Flooded	29.2	27.0	AGM / Gel	28.2	27.0
Battery Type	Boost CC/CV		Float												
	Voltage(V)	Voltage(V)													
	24	24													
Flooded	29.2	27.0													
AGM / Gel	28.2	27.0													
Charger current (+/-10%)	<p>The graphs illustrate the charge current (A) as a function of input voltage (Vac) for four different configurations:</p> <ul style="list-style-type: none"> Set as 20A & NOR range: Shows a constant charge current of 20A between 170V and 270V input voltage. Set as 20A & GEN/WID range: Shows a constant charge current of 20A between 170V and 270V input voltage, with a lower current of 10A between 90V and 100V. Set as 10A & NOR range: Shows a constant charge current of 10A between 170V and 270V input voltage. Set as 10A & GEN/WID range: Shows a constant charge current of 10A between 170V and 270V input voltage, with a lower current of 10A between 90V and 100V. 														

Note: NOR – Normal range; GEN-Generator range; WID-Wide range

Table 8 Approximate Back-up Times

Load(VA)	100Ah 24VDC(min)	200AH 24VDC(min)
300	457.5	972.2
600	208.1	499.5
900	140.6	262.3
1200	103	178.1
1500	77.8	138.3
1800	57.6	113.2
2100	49.5	100.5
2400	41.4	87.9
2700	33.2	75.3
3000	28.4	62.6

EN

Note: Back-up times depend on the quality of the battery, age of battery and type of battery. Specifications of batteries vary from one manufacturer to another.

Table 9 General Specifications

Safety Standard	EN60950-1:2006+A1: 2010 EN62040-1-1: 2008
EMC Standard	EN62040-2 : 2006 C2
Operating Temperature Range	0°C to 45°C
Storage temperature	-15°C~ 60°C
Altitude, operational	Elevation: 0 – 1500 Meters
Relative humidity	5% to 95% non-condensing
Audible Noise	60dB max
Cooling	Forced air
Dimension(L*W*H)	330mm*268mm*76mm
Net Weight	4.9KG
DC wiring	Double 6 AWG cable for each polarity
AC input/output	L/N/G:12AWG

Table 10 Fault code/ Audible alarm

Fault Code	Protect Function	Active Mode	Condition	Warning (O/P=ON)	Fault (O/P=OFF)	Restart	
						Operate	Condition
--	Low DC Voltage Alarm	Inverter	DC voltage<Low DC Alarm	1beep/2s	--	--	--
0	Low DC Voltage Protection	Inverter	DC Voltage<Low DC Shut-down	--	Beep continuous	Auto	Mains is normal
1	Over Charge Protection	Line	DC Voltage>High DC input Shut-down	Beep continuous	--	Manual	--
1	Over Voltage Protection	Standby	DC Voltage>High DC input Shut-down	--	Beep continuous	Auto	DC Voltage<High DC input Shut-down Recovery
2	Over Load Protection	Line/ Inverter	110%~150% load	1beep/0.5s,and continuous 10s	Beep continuous	Manual	--
		Line/ Inverter	>150% load	1beep/0.5s,and continuous 5s	Beep continuous	Manual	--
3	Output Short Circuit Protection	Inverter	1)Output Voltage<20Vrms 2)TX temperature>102°C	--	Beep continuous	Manual	--
4	Fan Fault Protection	Line/ Inverter	Fan Locked Fan Defected	2beep/2s, and continuous 1min	Beep continuous	Manual	--
5	Over Temp Protection	Line/ Inverter	HEAT SINK Temp \geq 100°C	--	Beep continuous	Auto	HEAT SINK Temp \leq 55°C
6	Output Abnormal	Inverter	1)Output Voltage<170Vrms or Output Voltage>250Vrms 2)TX temperature>102°C	--	Beep continuous	Manual	--

TROUBLE SHOOTING

Problem	Possible Causes	Remedy
No LCD display	1. Battery Weak	1. Re-charge battery
	2. Battery defective (can't be charged)	2. Battery replacement
	3. Power switch is not pressed	3. Press and hold power switch
	4. Battery polarity reversed, can't start up the unit	4. Sent back for repair
Mains normal but works in inverter mode	1. AC Input missing	1. Check AC input connection
	2. Input protector is effective	2. Reset the input protector
Mains normal but can't works in inverter mode	1. Battery disconnected	1. Connect batteries
	2. Low batteries	2. Recharge batteries or change new batteries
Alarm buzzer beeps continuously	1. Overload(fault code: F2)	1. Verify that the load matches the capability specified in the specs
	2. Output short circuit(fault code: F3)	2. Check wiring or remove abnormal load
	3. Over temp(fault code: F5)	3. Move away barrier in front of airflow inlet
	4. Over charger(fault code: F1)	4. Restart the unit
	5. Over voltage(fault code: F1)	5. Turn down the DC input voltage below the high DC input shut-down recovery
	6. Fan fault(fault code: F4)	6. Check if something block the fan, if not replace the fan
	7. DC voltage under the low DC shut-down(fault code: F0)	7. Make sure mains is normal to recharger the battery if not switch the power off until mains is normal
	8. Output abnormal(fault code: F6)	8. Send back for repair
Back up time is shortened	1. Overload	1. Remove some non-critical load
	2. Battery voltage is too low	2. Charge battery for 8 hours or more
	3. Battery bank is too small	3. Increase battery bank capacity